

GXDN フレキシブルチューブ直付型 標準型

防爆構造: d2G4

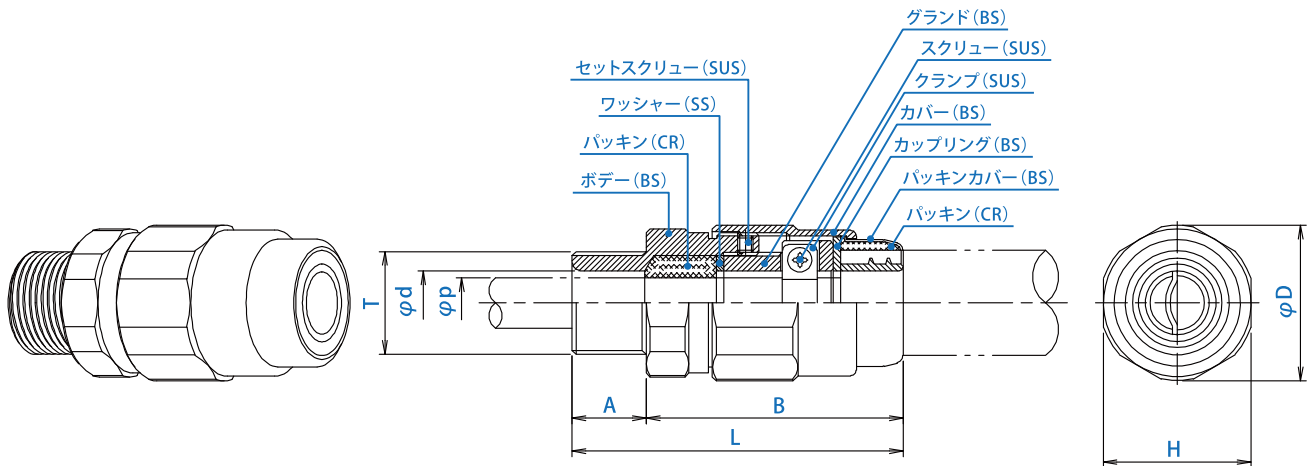
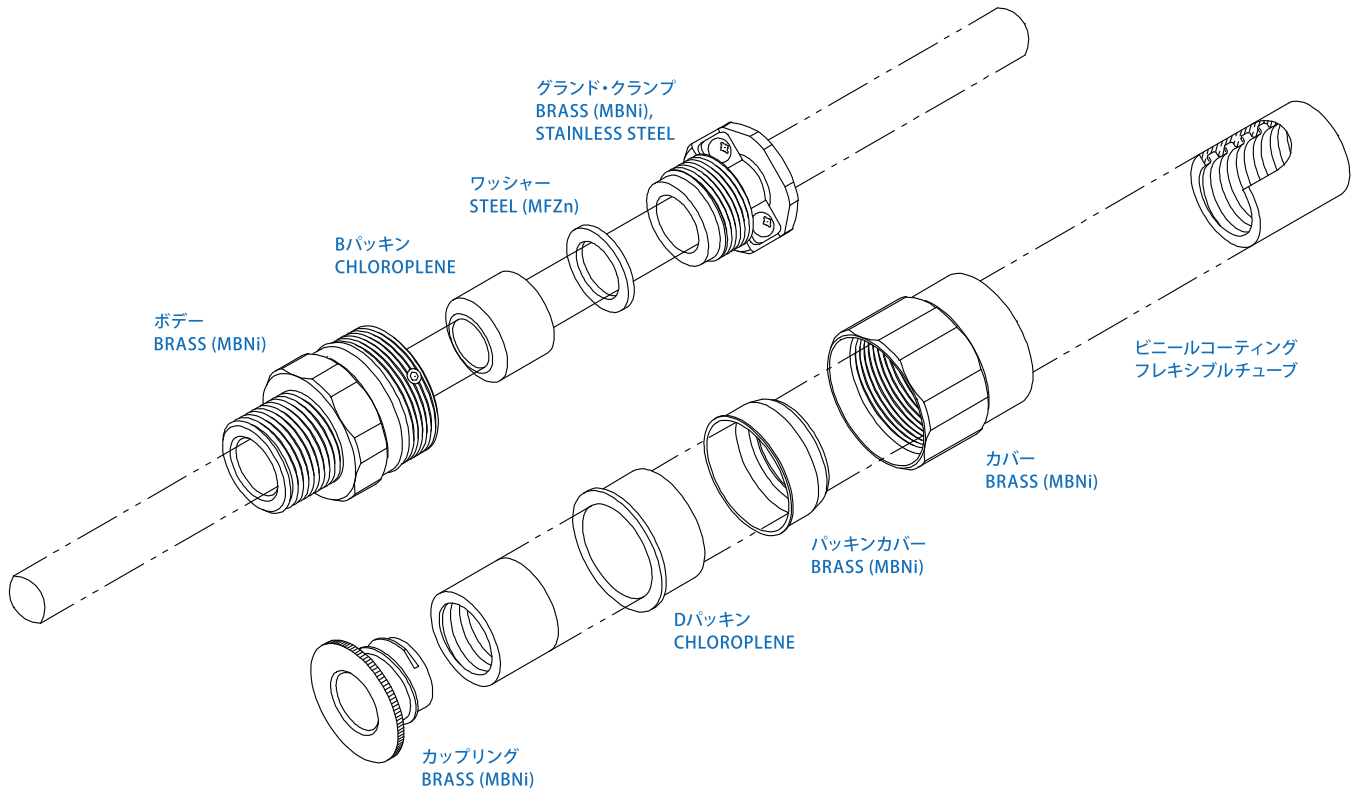

型式：寸法一覧表

表面処理：ニッケルメッキ

型式	接合ネジ		ケーブルグランド寸法 (mm)						質量 (kg)	パッキン内径寸法 (適合ケーブル範囲) φp (mm)					
	サイズ	T	A	B	L	φd	H	φD		P1	P2	P3	P4	P5	P6
GXDN09	16	G1/2	19	65	84	12.5	32	34	0.27	5 (5~4)	7 (7~5)	8 (8~6)	-	-	-
GXDN10	16	G1/2	19	65	84	12.5	32	34	0.27	-	-	9 (9~8)	10 (10~8)	11 (11~9)	12 (12~11)
GXDN20	22	G3/4	19	67	86	16.5	38	40	0.38	11 (11~10)	12 (12~10)	13 (13~11)	14 (14~12)	15 (15~13)	16 (16~15)
GXDN30	28	G1	24	72	96	21	46	49	0.57	14 (14~13)	16 (16~14)	17 (17~15)	18 (18~16)	19 (19~17)	20 (20~19)
GXDN40	36	G1 1/4	24	73	97	27	55	58	0.80	18 (18~17)	20 (20~18)	22 (22~20)	23 (23~21)	24 (24~22)	26 (26~24)
GXDN50	42	G1 1/2	25	79	104	31	62	65	1.10	22 (22~20)	24 (24~22)	26 (26~24)	27 (27~25)	28 (28~26)	30 (30~28)
GXDN60	54	G2	26	94	120	39	76	80	1.90	30 (30~28)	32 (32~30)	34 (34~32)	35 (35~33)	36 (36~34)	38 (38~36)